

## SOLAR RADIATION SENSOR

STANDARD & INDUSTRIAL

---

The Davis Solar Radiation Sensor is a precision instrument that detects radiation at wavelengths of 300 to 1100 nanometers. The spectral response of the silicon photodiode detector is a good match to the spectrum of solar irradiance.

The sensor is made up of the following components:

◆ **Shield**

The outer shell shields the sensor body from thermal radiation and provides a path for convection cooling of the body, minimizing heating of the sensor interior. It provides a cutoff ring for cosine response, a level indicator, and fins to aid in aligning the sensor with the sun's rays.

◆ **Body**

The body houses the following components:

◆ **Diffuser**

Welded to the body for a weather-tight seal. Provides excellent cosine response.

◆ **Detector**

An hermetically-sealed silicon photodiode.

◆ **Amplifier**

The amplifier converts the detector current into a 0 to +2.5V signal.

◆ **Cable**

The standard version of the sensor includes an attached 40' (12 m) standard cable. The industrial version includes a 16' (5 m) shielded cable.

---

## COMPONENTS

Please make sure you have all components listed below before continuing.

- ◆ Shield
- ◆ Body with cable attached
- ◆ Mounting Hardware  
Enables installation and leveling of the sensor.
  - ◆ Three #6-32 x 1-1/2" Machine Screws
  - ◆ Three Springs
  - ◆ Three #6 Flat Washers
  - ◆ Three #6 Screw Retainers
  - ◆ Three #4 Screw Retainers
  - ◆ Three Wood Screws
  - ◆ One #8-32 x 3/4" Machine Screw
  - ◆ One #8 Hex Nut
  - ◆ One #8 Flat Washer
  - ◆ One 3/16" Cable Clamp

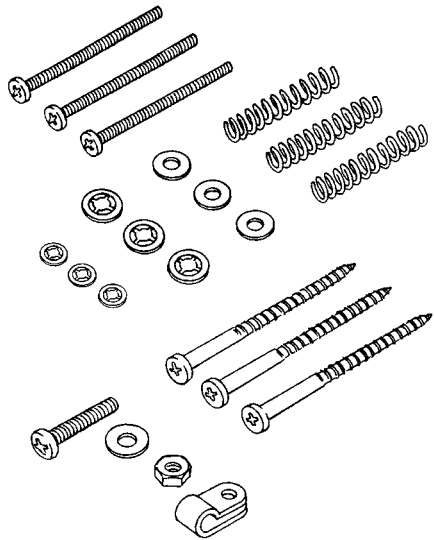

## TOOLS AND MATERIALS NEEDED

You may need some of the following tools and materials in order to complete your installation. Please be sure you have everything you need before beginning.

- ◆ Medium Phillips Screwdriver
- ◆ Center Punch or Nail (if mounting on wood surface)
- ◆ Drill with 7/8" (22 mm) and #36 (2.7 mm) Drill Bits (if mounting on wood surface)
- ◆ Wire Cutters and Stripper (Industrial version only)

## TESTING THE SENSOR

You may test the sensor before you install it or you may test it after installing it. The instructions below provide a quick description of the suggested test procedure.

1. Attach the sensor cable to the connector S5 on the sensor interface module.  
Consult the System Installation manual for instructions
2. Press the appropriate key to make sure you are getting a solar radiation reading on the console.  
Consult the station manual for instructions on displaying solar radiation.
3. Shade the sensor and make sure the reading changes.

---

## INSTALLING THE SENSOR

Follow the instructions in this section to install your sensor. Before you begin, consult the System Installation manual for instructions on labeling the sensor cable.

- ◆ For ET or scientific measurements, the sensor can be mounted on the Sensor Mounting Arm or any level surface.
- ◆ For measurements where the immediate effect on humans is of interest, we recommend that you mount the sensor such that its axis is aligned with the sun's rays at solar noon. This will maximize the mid-day readings and provide what is probably a more accurate measure of the sun's effect on people exposed to it. The Health EnviroMonitor™ calculation of the solar radiation contribution to apparent temperature assumes that the sensor is tilted. The Sensor Tilting Bracket (7706) is designed for this purpose.
- ◆ Similarly, if you wish to predict or monitor the irradiance on a solar voltaic or thermal collection panel the data are probably most relevant if the sensor is tilted to the same angle as the collection panel. The Sensor Tilting Bracket (7706) is designed for this purpose.

### Typical Standard Installation

The illustration below shows typical standard solar radiation installation. The sensor cable attaches to connector S5 on the sensor interface module (SIM).

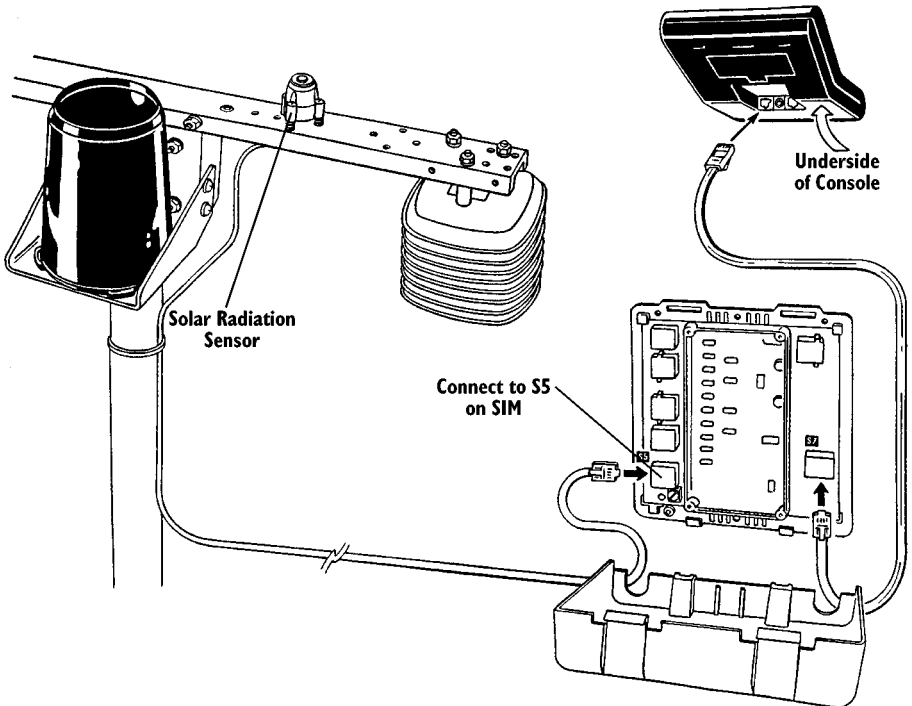

TYPICAL STANDARD INSTALLATION

---

## Typical Industrial Installation

The illustration below shows typical industrial solar radiation installation. The sensor cable attaches to connector S5 on the sensor interface module (SIM).

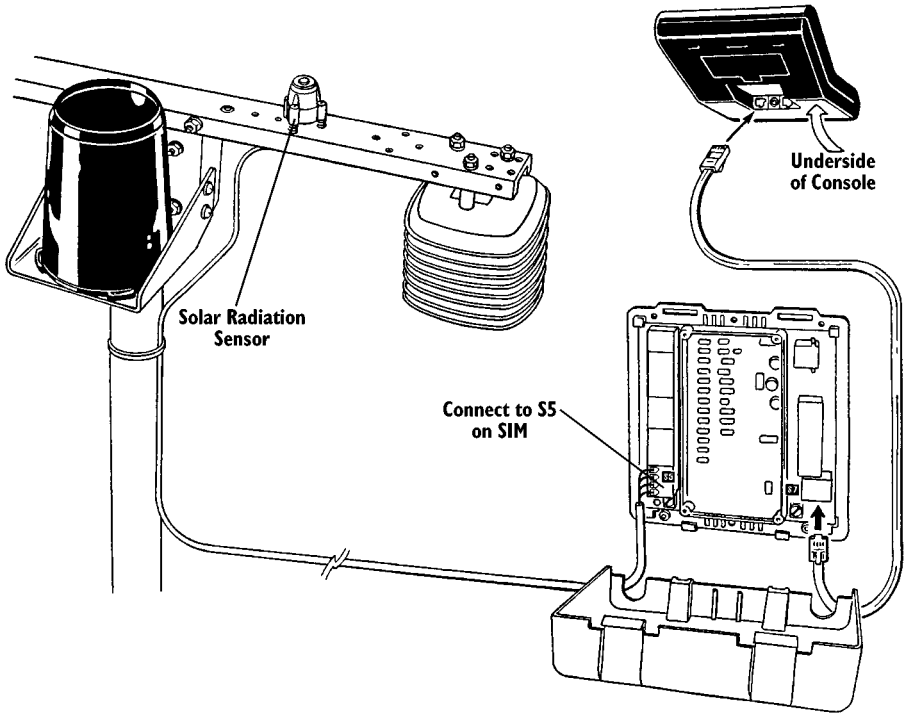

*TYPICAL INDUSTRIAL INSTALLATION*

---

## Mounting the Sensor on the Sensor Mounting Arm

Follow the instructions below to mount the sensor on the Sensor Mounting Arm (SMA).

1. Route the cable through the large hole in the mounting arm if desired.
2. Place the shield onto the body as shown below.

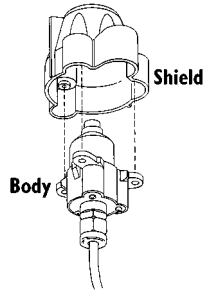

*PLACING SHIELD ONTO BODY*

3. Place a flat washer over the end of each screw and insert it into the body.
4. Place a spring over the end of each screw and hold the springs in place using a #6 screw retainer.
5. Secure the sensor to the mounting arm by driving the screws into the appropriate holes as shown below.

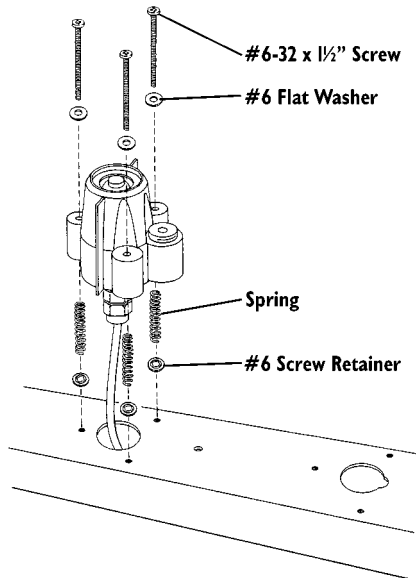

*MOUNTING THE SOLAR RADIATION SENSOR ON THE SMA*

6. Using the bubble level on the sensor as a guide, adjust the sensor until it is level by tightening or loosening the levelling screws as necessary.

- 
7. Secure the sensor cable to the underside of the mounting arm using the 3/16" cable clamp, #8-32 x 3/4" screw, #8 hex nut, and #8 flat washer as shown below.

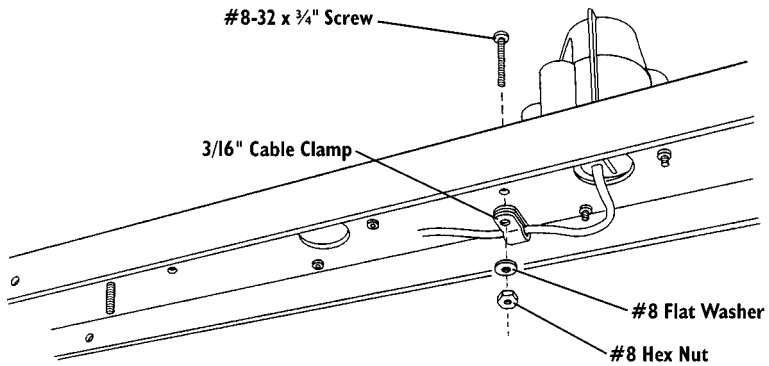

*SECURING SENSOR CABLE*

### Mounting the Sensor on the Sensor Tilting Bracket

Follow the instructions below to mount the sensor on the Sensor Tilting Bracket. Do not install the bracket onto the mounting arm until instructed to do so below.

1. Route the cable through the large hole in the bracket if desired.
2. Place the shield onto the body as shown below.

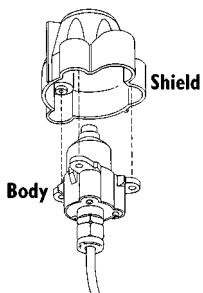

*PLACING SHIELD ONTO BODY*

3. Place a flat washer over the end of each screw and insert it into the body.
4. Place a spring over the end of each screw and hold the springs in place using a #6 screw retainer.
5. Secure the sensor to the bracket by driving the screws into the appropriate holes as shown below.

If mounting the sensor on the tilting bracket in a location under 46° latitude or in a situation which requires the angle of the tilting bracket to be less than 28°, you will need to use the standoffs supplied with the tilting bracket. Consult the Sensor Tilting Bracket manual for details..

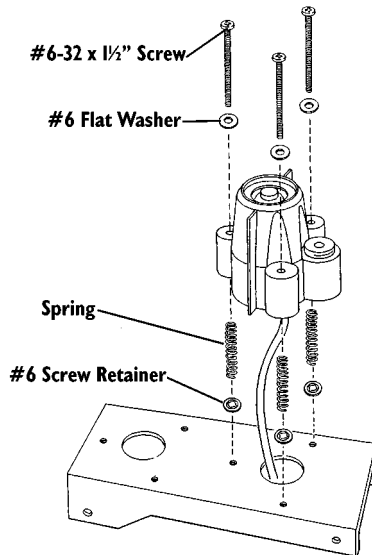

*MOUNTING THE SOLAR RADIATION SENSOR ON THE SENSOR TILTING BRACKET*

6. Position the Sensor Mounting Arm so it is pointed in the direction of the sun at solar noon.

Solar noon occurs halfway between sunrise and sunset; consult your local paper or the WeatherLink® software for sunrise and sunset times. To correctly align the arm, screw a mounting screw part way into any of the sensor's screw positions on the mounting arm and rotate the arm until the shadow from the screw is parallel to the edge of the sensor arm at solar noon.

7. Attach the bracket to the mounting arm as described in the Sensor Tilting Bracket instruction manual.

If you are installing both the solar radiation and the UV sensor on the sensor tilting bracket, make sure you mount the solar radiation sensor on the sensor tilting bracket before attaching to the sensor mounting arm.

8. If necessary, adjust the position of the sensor by tightening or loosening the levelling screws.

When pointed directly at the sun, the shadows from the alignment fins should appear as shown in the illustration below.

**Step #1: Adjust side screws until fin shadows are equal.**

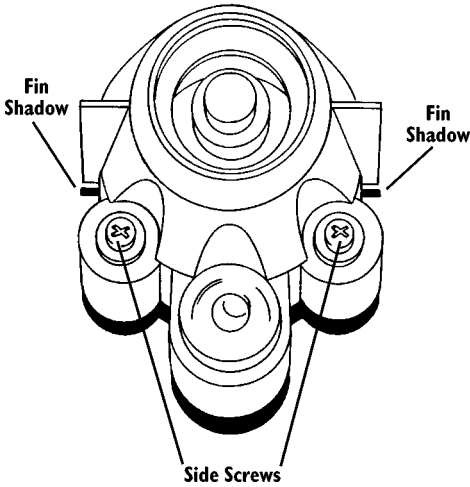

**Step #2: Adjust back screw to minimize fin shadows.**

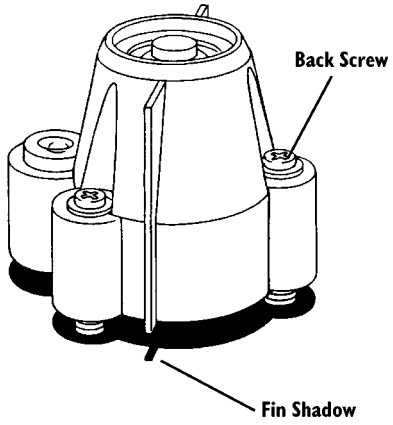

FINAL SENSOR POSITIONING

9. Secure the sensor cable to the underside of the mounting arm using the 3/16" cable clamp, #8-32 x 3/4" screw, #8 hex nut, and #8 flat washer as shown below.

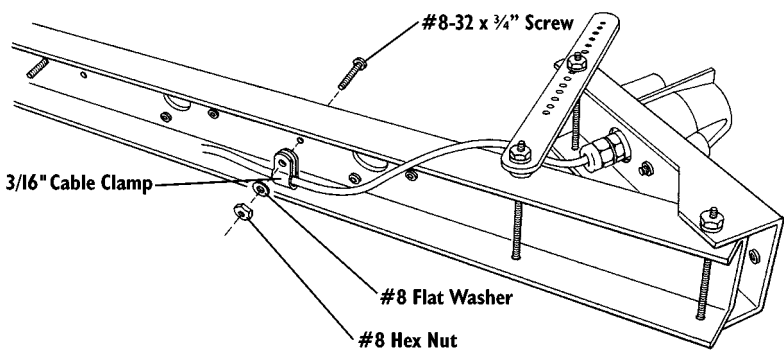

SECURING SENSOR CABLE

---

## Mounting the Sensor on a Wood Surface

Follow the instructions below to mount the sensor on a wood surface.

1. Using the template printed at the bottom of this page, mark the location of the necessary pilot holes.
2. Using a drill with a #36 (2.7 mm) drill bit, drill pilot hole in the marked locations. If necessary, bore a hole through the mounting surface using a 7/8" (22 mm) drill bit so the bottom of the sensor can sit inside of it and the sensor cable can run to the other side.
3. Route the sensor cable through the hole in the wood if desired.
4. Place the shield onto the body as shown below.

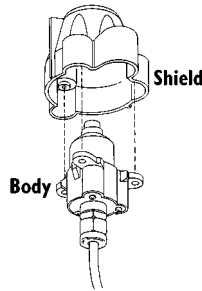

*PLACING SHIELD ONTO BODY*

5. Place a flat washer over the end of each screw and insert it into the body.
6. Place a spring over the end of each screw and hold the springs in place using a #4 screw retainer.

---

Use the template below to center-punch or mark pilot holes before drilling.

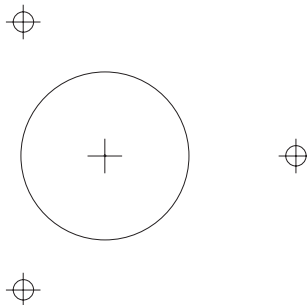

*SOLAR RADIATION SENSOR MOUNTING HOLES TEMPLATE*

- 
7. Secure the sensor to the mounting surface by driving the screws into the appropriate holes as shown below.

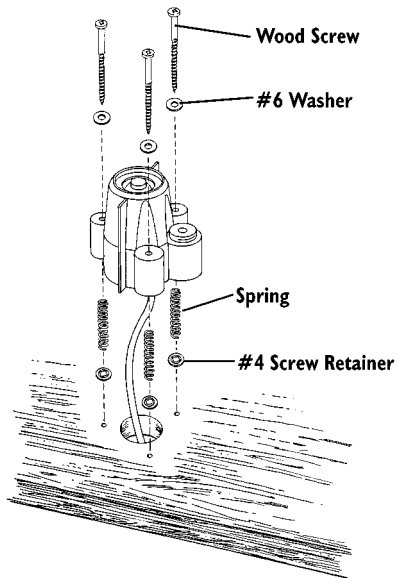

*MOUNTING THE SOLAR RADIATION SENSOR ON A WOOD SURFACE*

8. Using the bubble level on the sensor as a guide, adjust the sensor until it is level by tightening or loosening the levelling screws as necessary.
9. Secure the sensor cable to the mounting surface. You may use the provided 3/16" cable clamp, #8-32 x 3/4" screw, #8 hex nut, and #8 flat washer if possible. Otherwise, you may need to supply your own hardware.

---

## Routing Sensor Cable

To prevent fraying or cutting of the cable where it is exposed to weather, it is important that you secure it so it doesn't whip about in the wind. For example, you might want to use cable clips or weather resistant cable ties to secure the cable. Place clips or ties approximately every 3 to 5 feet (1 to 1.6 m). Do not use metal staples or a staple gun to secure cables. Metal staples—especially when installed with a staple gun—have a tendency to cut the cables.

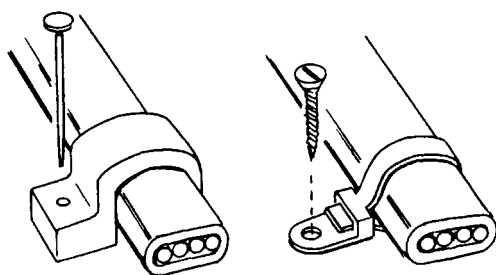

SECURING CABLE (STANDARD CABLE SHOWN)

---

**Note:** When running the sensor cable, try not to tug on the cable in such a way as to loosen the connections between cables. Also, make sure the sensor cable is not so taut that connections loosen or pull free due to the strain. Many sensor problems occur because cable connections come loose. If you need to check your cable connection to the sensor itself, see the section below.

---

## MAINTAINING THE SENSOR

Solar radiation sensors should be calibrated once every year. The date of manufacture appears on the sensor's manufacturing label. Each year (on approximately that date) you should contact Davis Technical Support (1-510-732-7814) about returning your sensor for calibration.

## TECHNICAL SUPPORT

Before calling Technical Support (1-510-732-7814) regarding a problem with your sensor, carefully check all cable connections from the sensor to the console. Cable connections account for a large portion of the potential problems. Connections should be firmly seated in the jacks and plugged in straight. If you think a connection may be faulty, try jiggling the cable while looking at the display. If a reading appears intermittently on the display as you jiggle the cable, the connection is faulty.

---

Product Numbers: 7821 & 7823

Davis Instruments Part Number: 7395-092  
Solar Radiation Sensor, Standard and Industrial  
Rev. B Manual (7/8/99)

This product complies with the essential protection requirements of the EC EMC  
Directive 89/336/EC.

© Davis Instruments Corp. 1997. All rights reserved.

**DAVIS**   
**Davis Instruments**

3465 Diablo Avenue, Hayward, CA 94545 U.S.A.